

Received June 27, 2016, accepted July 8, 2016, date of publication August 24, 2016, date of current version October 15, 2016.

Digital Object Identifier 10.1109/ACCESS.2016.2602281

On Quality-of-Service Provisioning in IEEE 802.11ax WLANs

DER-JIUNN DENG¹, (Member, IEEE), SHAO-YU LIEN², JORDEN LEE³, AND KWANG-CHENG CHEN^{3,4}, (Fellow, IEEE)

¹Department of Computer Science and Information Engineering, National Changhua University of Education, Changhua 500, Taiwan

²Department of Electronic and Engineering, National Formosa University, Yunlin 632, Taiwan

³Graduate Institute of Communication Engineering, National Taiwan University, Taipei 10617, Taiwan

⁴Department of Electrical Engineering, University of South Florida, Tampa, FL 33620, USA

Corresponding author: D.-J. Deng (djdeng@cc.ncue.edu.tw)

This work was supported by Huawei Corporation.

ABSTRACT A revolutionary effort to seek fundamental improvement of 802.11, known as IEEE 802.11ax, has been approved to deliver the next-generation wireless local area network (WLAN) technologies. In WLANs, medium access control protocol is the key component that enables efficient sharing the common radio channel while satisfying the quality of service (QoS) requirements for multimedia applications. With the new physical layer design and subsequent new medium access control functions under more demands on QoS and user experience, in this paper, we first survey the QoS support in legacy 802.11. Then, we summarize the IEEE 802.11ax standardization activities in progress and present an overview of current perspectives and expected features on medium access control protocol design to better support QoS and user experience in 802.11ax. We present the motivation behind, explain design principles, and identify new research challenges. To better satisfy customer needs on high bandwidth and low latency, emerging long-term evolution licensed-assisted access and its impacts to QoS provisioning in IEEE 802.11ax are further addressed given the collaboration between cellular and WLANs, and given the trend of 5G cellular over unlicensed bands.

INDEX TERMS Quality of service, IEEE 802.11ax, LTE-LAA, 5G, 5G-unlicensed, medium access control, wireless local area networks, WiFi, heterogeneous networks.

I. THE FIRST DECADE OF Wi-Fi

The standardization of wireless local area networks (WLANs) or nick named as Wireless Fidelity (Wi-Fi) could be traced back to a sub-committee of 802.4 (Token Bus), 802.4L, in 1988, and a new working group IEEE 802.11 has been established to develop various WLAN standards since 1990. The first version of the IEEE 802.11 standard that was released in 1997 supported 1 and 2 Mbit/s physical link speeds. It included the physical layer (PHY) adopting direct sequence spread spectrum communication, frequency hopping spread spectrum communication, and nondirective infrared transmission technologies, while a single medium access control sub-layer (MAC) specification to provide wireless connectivity for fixed, portable, nomadic and moving stations within a local area. IEEE 802.11 MAC fundamentally operates on the distributed coordinated function (DCF), which adopts carrier sense multiple access with collision avoidance (CSMA/CA). Together with 4-way

handshaking procedure, IEEE 802.11 MAC allows more reliable operation to accommodate challenging fading and interference in wireless channels [1]. IEEE 802.11 standard later evolves into many amendments, particularly for higher speed physical layer transmissions using orthogonal frequency division multiplexing (OFDM), multiple-antenna techniques, and space-time codes, namely IEEE 802.11a, 802.11b, 802.11g, 802.11n, 802.11ac. After wide deployment, more amendments have been developed for the enhancement of higher level service support such as 802.11i (security) and 802.11e (quality of service), 802.11p for wireless access in Vehicular Ad Hoc Networks (VANETs), and 802.11s for mesh networking. The list of most popular past and present IEEE 802.11 amendments is shown in Table 1 [2].

Since the first technically approved draft of the IEEE 802.11, the WLANs have experienced tremendous growth with the proliferation of Wi-Fi devices as a major Internet access for mobile computing. Evolving of

TABLE 1. Early approved IEEE 802.11 amendments.

802.11 Amendments	Responsibility
802.11a Approved in 1999	Specification enabling up to 54 Mb/s to be achieved in the 5 GHz unlicensed radio band by utilizing OFDM.
802.11b Approved in 1999	Specification enabling up to 11 Mb/s to be achieved in the 2.4 GHz unlicensed radio band by utilizing HR/DSSS.
802.11d Approved in 2001	Covers additional regulatory domains, which facilitates the development of WLAN devices that comply with the wireless communications regulations of their respective countries.
802.11c Approved in 2001	Provides required information to ensure proper bridge operations, which is required when developing access points.
802.11f Approved in 2003	Covers Inter Access Point Protocol (IAPP), ensuring the user can roam in the different access points.
802.11g Approved in 2003	Specification enabling high data rate up to 54 Mb/s to be achieved in the 2.4 GHz unlicensed radio band.
802.11h Approved in 2003	Covers dynamic frequency selection (DFS) and transmit power control (TPC), the protocol solves the interferential problem of satellites and radar that using the identical 5 GHz frequency band.
802.11i Approved in 2004	Enhance WLAN security to replace the previous security specification Wired Equivalent Privacy (WEP).
802.11j Approved in 2004	Specially designed for Japanese market. It allows Wireless LAN operation in the 4.9 to 5 GHz band.
802.11e Approved in 2005	Defining a set of Quality of Service (QoS) enhancements for wireless LAN applications through modifications to the Media Access Control (MAC) layer.
802.11r Approved in 2008	Provide the fast and secure handoffs from one base station to another managed in a seamless manner.
802.11n Approved in 2009	Supporting for multiple-input multiple-output(MIMO) and security improvements utilized in the 2.4 GHz or 5 GHz frequency bands and the transmission speed is greater than 100 Mb/s.
802.11p Approved in 2010	For wireless access technology applied on wireless access in vehicular environments (WAVE), defined the architecture of communications system and a series of standardized services.
802.11s Approved in 2011	Defining the wireless mesh network, the wireless devices can interconnect to create a wireless mesh network.

WLAN technologies have focused on multiple aspects in terms of data rate, security, efficiency, etc. IEEE 802.11 Working Group (WG) recently celebrated its 25th anniversary during July 2015 at a plenary session in Waikoloa, Hawaii. From the first quarter of century to the second quarter century for IEEE 802.11, both physical layer transmission (PHY) and medium access control (MAC) have experienced some fundamental changes, particularly in the IEEE 802.11 ax that is expected to be the next main stream wireless technology with cellular systems. A milestone analysis on the IEEE 802.11 MAC [3] enables more detailed study on quality of service (QoS) performance. As social media is dominating Internet traffic, in the following, we shall focus on the aspect regarding QoS for the next generation WLANs, 802.11ax, which revolutionarily employs multiuser PHY in both uplink and downlink. Readers may consult [2], [4] regarding more new features and other new technological challenges in designing IEEE 802.11ax.

II. QUALITY-OF-SERVICE IN IEEE 802.11

In the past, network designers had to contend with only one form of traffic, voice or data. Today's applications become much richer in content and more diverse in traffic patterns, while latency or delay plays a critical role in user experience.

In general, there are two methodologies in wireless MAC to serve time-bounded data, reservation schemes and priority schemes. Reservation schemes allow time-bounded traffic to reserve a periodic time slot or a dedicated sub-carrier on the channel. Priority schemes, by contrast, share resources and at the same time allow some users to have a larger share of the pie. They assign higher priority to the time-bounded traffic such that time-bounded data has precedence for using network resources. However, depending on the protocol design (for example, whether the resource usage is preemptive), performance cannot be guaranteed [5].

The fundamental access method of the 802.11 MAC, DCF, is designed for best effort service only, while time-bounded traffic relies on an alternative access method, point coordination function (PCF), offering the centralized realization of "packet-switched connection-oriented" services. However, complete implementation involves maintenance of polling list, admission control, and packet scheduling policy to facilitate interoperable devices is beyond the scope of typical IEEE 802.11 protocol stack and thus seldom used in modern WLANs.

During the last decade, lots efforts have been devoted to improving QoS support in WLANs [6], [7]. One of the most important milestones was the IEEE 802.11e amendment

which defined several mechanisms for providing QoS support [8]. To expand support for applications with QoS requirements, the IEEE 802.11e amendment has been approved in 2005 to provide integrated traffic service to realize mobile multimedia communications. IEEE 802.11e includes two coordination functions, Enhanced Distributed Channel Access (EDCA) and Hybrid Coordination Function Controlled Channel Access (HCCA). The basic idea behind EDCA is that the prioritized access to the medium is provided by allowing shorter average waiting time, smaller Contention Window (CW) size or smaller Inter-Frame Space (IFS), for high priority stations. In general, differentiating the CW size is better than differentiating the IFS in terms of total throughput and delay. The reason is that differentiating the CW size have both the function of reducing collisions and providing priorities, whereas differentiating the IFS has the function of providing priorities, but cannot reduce collisions. Most importantly, EDCA can not provide guaranteed QoS because it is based on random access.

A simple call admission control (CAC) scheme and packet scheduling policy has been developed as a reference in the IEEE 802.11e HCCA access method [9], where the mean data rate and the mean packet size are used to calculate the resource need by multimedia traffic. However, a guaranteed stringent delay constraint for every single packet to provide multimedia traffic with their pledged QoS requirements still cannot be satisfied since the instantaneous and fluctuating data rate generated by multimedia applications are usually quite different from the corresponding mean values. Hence, choosing the right set of CAC scheme and packet scheduling policy to provide predictable QoS in WLANs remains unsolved.

Another important related document was the the IEEE 802.11s amendment [10] as it try to extend QoS to multi-hop environment. To provide QoS in such networks is much more complex and, in fact, this problem has not been completely solved yet. To provide a mechanism for the reliable transmission of multicast streams in WLANs and to address the overlapping basic service set (OBSS) management, a new task group IEEE 802.11aa [11] was created to develop a set of enhancements for robust multimedia streaming. In IEEE 802.11aa, the channel selection mechanism is used to avoid over allocation of the radio resource. In addition, Access Point (AP) cooperation is used to ensure that each AP has a fair share of the bandwidth, and at the same time to protect the admitted or allocated QoS streams from impairment by the addition of streams from other OBSS. Another recognized problem that degrades QoS in WLANs is related to the control frames. According to the current standard, control frames in WLANs are transmitted with the highest priority, and this could interfere with the transmission of multimedia traffic. Hence, another task group 802.11ae [12] was also created to develop flexible prioritization mechanisms for control frames.

In the past, QoS management generally focus on allocating radio resources to requested services, which are usually

driven by some QoS parameters, such as access/transmission delay, jitter and packet loss rate. Nevertheless, this falls short on providing better quality-of-experience (QoE) since it does not consider each end user's perception of service quality. QoE is a measure or assessment of the human experience when interacting with technology and business entities in a particular context. It describes the overall acceptability of service quality from the end user's point of view since service quality ultimately is measured by the end user's experience. For this reason, researchers started to consider QoE on designing radio resource management to provide better multimedia experience [13]. However, to optimize end users' multimedia experience, such initial QoE conceptualization requires further enhancement and improvement.

III. CHALLENGES OF IEEE 802.11 IN DENSE DEPLOYMENT

After wide deployment of Wi-Fi, we are facing some fundamental technology challenges especially in dense environment. One main reason is that although now IEEE 802.11 has multiple PHY options, but there is only one common MAC option, carrier sense multiple access with collision avoidance (CSMA/CA), as shown in Fig. 1.

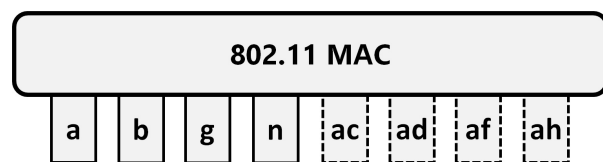

FIGURE 1. One common MAC over multiple PHY options.

In realistic dense IEEE 802.11 networks, high network throughput does not necessarily translate to sufficient bandwidth and thus satisfactory delay/latency for nice user experience. Even worse, connectivity could be lost in many cases. The root-causes include:

A. SEVERE COLLISIONS FROM CHANNEL CONTENTION

As the current WLANs adopting IFS and CW to effectively control the MAC operation, vulnerability under dense deployment arises as a common troublesome since the MAC parameters of its collision avoidance/resolution mechanism are far from the optimal setting. To begin with, the fundamental access method of IEEE 802.11, CSMA/CA, might incur with a high collision probability in dense scenarios and thus degrade the channel utilization. This is because MAC selects a small initial value of CW size by a naive assumption of a low level of congestion in the system. Second, CSMA/CA might lead to the “fairness problem” because its collision resolution algorithm, binary exponential backoff (BEB) algorithm, always favors the last successfully transmitted station. Finally, frame loss is another key factor diminishing the performance since MAC does not take into account the occurrence of non-collision losses. Unfortunately, wireless links are noisy and highly unreliable. Path loss, channel noise,

fading, and interference may cause significant transmission errors. If the sender is unable to distinguish the causes of frame loss, it is difficult to make the right decision. To detect erratic errors and frame loss, an intelligent and cognitive protocol is therefore needed to ensure the system performance demanded by applications.

In [14], a theoretical upper bound of achievable throughput of DCF access method was computed, and it is reported that the achievable throughput of DCF access method is far from its theoretical limit and its performance can be improved by reducing the time spent for negotiating channel access, for example, collision resolution and contention alleviation. In other words, by appropriately tuning the CW size, the DCF access method can achieve better performance and operate close to its theoretical limit.

Most existing CW control mechanisms can be classified into two categories, namely semi-dynamic [15] and quasi-dynamic [14], [16] approaches, according to the methodology used for CW controlling. In general, quasi-dynamic approaches tend to achieve better performance than semi-dynamic approaches because they can operate according to the observed actual channel conditions. However, in addition to the difficulties in acquiring sufficient knowledge of the system, these type of approximations tend to be very computationally complex, and subject to significant errors, especially in dense scenarios. Furthermore, almost all the quasi-dynamic approaches require the knowledge of the number of contending stations, which is difficult to predict in the absence of a central coordinator.

Although in early study [3] the author had already pointed out that if n is the estimated number of active stations and a average transmission takes T slot times, the optimal contention window size is given by $W_{opt} = n\sqrt{2T}$, this is based on the saturation analysis, and the traffic pattern is not considered. Hence, it is unlikely to be valid in real WLANs.

B. INCREASED INTERFERENCE FROM NEIGHBORING DEVICES

Multiple BSSs with high density deployment may result in an overlap of adjacent BSSs, which cause inter-BSS interference. Request-to-Send (RTS)/Clear-to-Send (CTS) mechanism is proposed to solve hidden terminal problem and enhance transferring performance. Hidden terminal problem occurs when there is a station in a service set, while trying to detect whether the channel is busy, is not aware of the ongoing transmission of another station. However, research demonstrates while RTS/CTS mechanism can only partly overcome hidden node problem. However, performance of the system performance decreases as well. This is because overhead brought by RTS and CTS frames might relatively occupy bandwidth and consequently lower the network throughput. In addition, RTS/CTS frames might not be able to solve another problem called the exposed terminal problem in which a mobile station that is nearby, but is associated with another AP which overhears the exchange and then is

signaled to backoff and cease transmitting for the time specified in the RTS.

Another way to improve performance in dense environment is to increase spatial reuse by adopting dynamic Clear Channel Assessment (CCA). CCA is the method to determine transmission opportunity with CSMA, which is a fundamental mechanism for legacy IEEE 802.11 MAC. Some recent studies argued whether the current CCA threshold of -82dBm is optimum, and whether it should be dynamic. For example, in [17], a heuristic algorithm that dynamically tunes the CCA threshold is proposed for QoS provisioning in homogeneous networks. However, dynamic CCA might degrade aggregate network throughput because, to gain more opportunities to transmit, every mobile station is inclined to use the highest CCA level allowed by reducing its modulation and coding scheme (MCS) [18]. Furthermore, sometimes energy detection is not reliable for CCA in dense deployment because CCA is based on the energy received from the transmitter, irrespective of the recipient, as shown in Fig. 2. Hence, due to the dynamic nature of wireless channel, there is no specific answer so far about how to find an optimum CCA that depends on multiple factors, say frequency, topology, transmission power, etc.

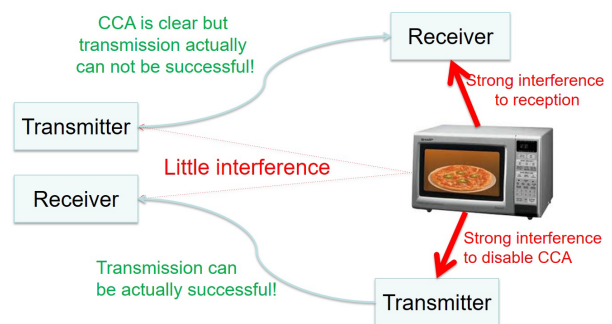
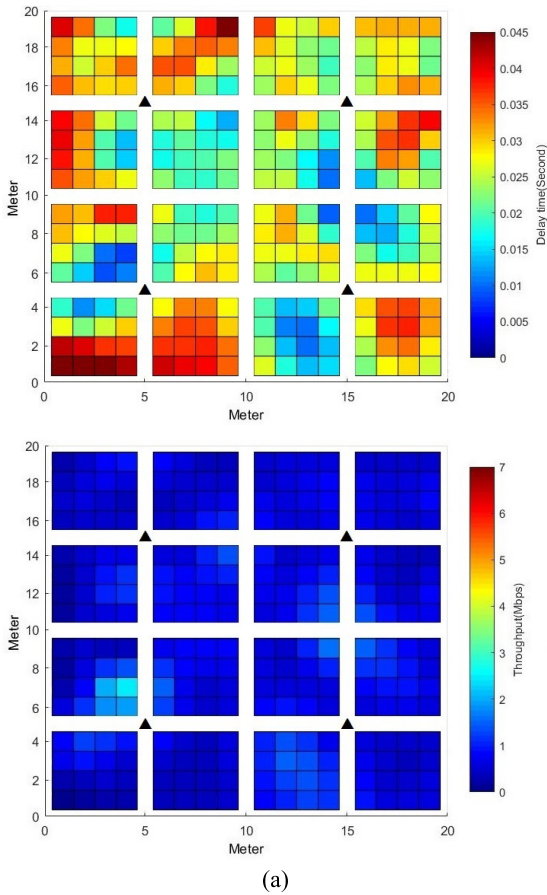

FIGURE 2. Unreliable energy sensing of CCA.

In order to study the performance of legacy IEEE 802.11 in dense deployment, we use our custom event-driven C++ simulator to run simulation in an enterprise scenario which was defined by IEEE 802.11ax Task Group [19]. The result is presented in Fig. 3 (a) and the topology we used is provided in Fig. 3 (b). The simulation results verify collisions and interferences are indeed the major reasons for performance loss. Some other observations from the simulation results include:

- 1) system performance improves as the number of APs increases in dense scenario,
- 2) system performance deteriorates significantly as the number of mobile stations increases in dense scenario,
- 3) RTS/CTS mechanism improves system throughput at the cost of higher delay/jitter in dense scenario, and
- 4) mobile stations in the overlapping coverage area between BSSs suffer higher interference.



(a) Throughput and delay for IEEE 802.11 in dense environment.
 (b) Station clusters and AP positions.

FIGURE 3. Simulation result and topology used in simulation.
(a) Throughput and delay for IEEE 802.11 in dense environment.
(b) Station clusters and AP positions.

IV. BEYOND IEEE 802.11ac

To provide larger bandwidth and higher data rate, IEEE 802.11ac, the latest approved IEEE 802.11ax amendment, has been developed with the goal of reaching maximum

aggregate network throughput of at least 1 gigabit per second on unlicensed bands at 5 GHz band. This is accomplished by extending the air interface concepts embraced by IEEE 802.11n: wider channel bandwidth (20/40/80/160/80+80 MHz), more multiple-input multiple-output (MIMO) spatial streams (up to eight antennas), and high-density modulation (up to 256-QAM). In particular downlink (DL) multi-user (MU) MIMO technology (up to four clients) has been adopted to improve the spectrum efficiency by allowing simultaneous transmissions of multiple data frames to different stations. The first generation IEEE 802.11ac technical solutions are already available in the market.

In the past, the standardization efforts have been very much focused on increasing the link throughput, rather than efficient use of spectrum and user experience such as delay and latency. Nowadays, Wi-Fi are currently being deployed in dense and diverse environments. These environments are characterized by the existence of many APs and mobile stations in geographically limited areas. Severe collisions from channel contention and increased interference from neighboring devices give rise to system performance degradation. In addition, WLAN devices are increasingly required to support a variety of applications such as voice, video, cloud access, and traffic offloading. While cellular companies are planning to kick off LTE-A service and offering up to 1 gigabit per second data rate in the next few years, Wi-Fi also needs upgrade to support increasing demands of system performance by emerging applications, including improved power consumption for battery-operated devices, as shown in Fig. 4.

The IEEE Standards Association (IEEE-SA) standards board approved IEEE 802.11ax in March, 2014. The scope of 802.11ax amendment is to define standardized modifications to both PHY and MAC layer that enable at least one mode of operation capable of supporting at least four times improvement in the average throughput per station in a dense deployment scenario, while maintaining or improving the power efficiency per station. In particularly IEEE 802.11ax focuses on improving metrics that reflect user experience. This is accomplished by efficiently use the spectrum, spatial reuse and interference management, and MAC enhancements. The new amendment shall enable backward compatibility and coexistence with legacy IEEE 802.11 devices operating in the same band. The evolution of Wi-Fi technology is illustrated in Fig. 5. IEEE 802.11ax study group was initiated in 2013. Submission of draft to the IEEE-SA for initial sponsor ballot is expected as early as January, 2018. It is anticipated that actual deployment of the standard will take place in the middle of 2019. Fig. 6 illustrates the timeline and progress toward the IEEE 802.11ax standard.

Apart from IEEE 802.11ax, IEEE 802.11 WG is also crafting other 802.11 amendments. Table 2 shows the PHY standard of some most significant released and upcoming IEEE 802.11 amendments.

IEEE 802.11ad amendment deals with 60 GHz wireless operations since 60 GHz will be another spectrum band

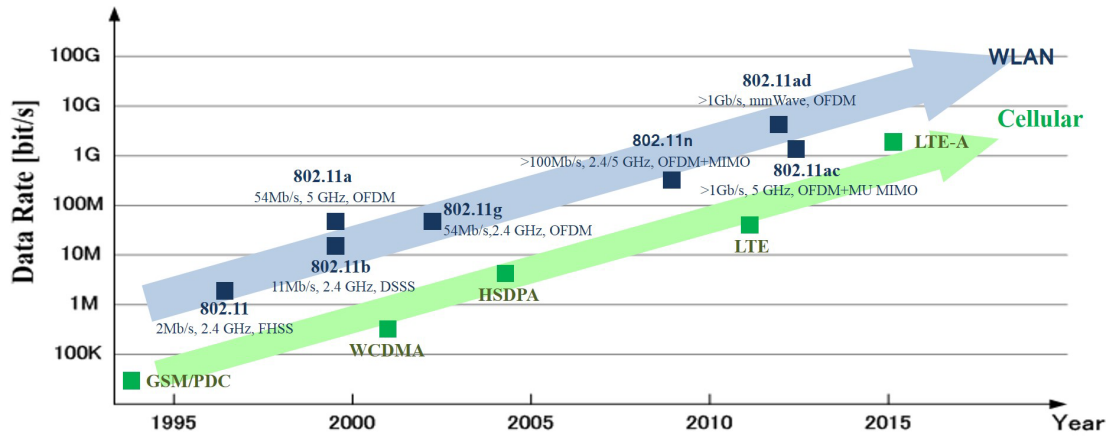

FIGURE 4. Evolution of wireless communication protocols.

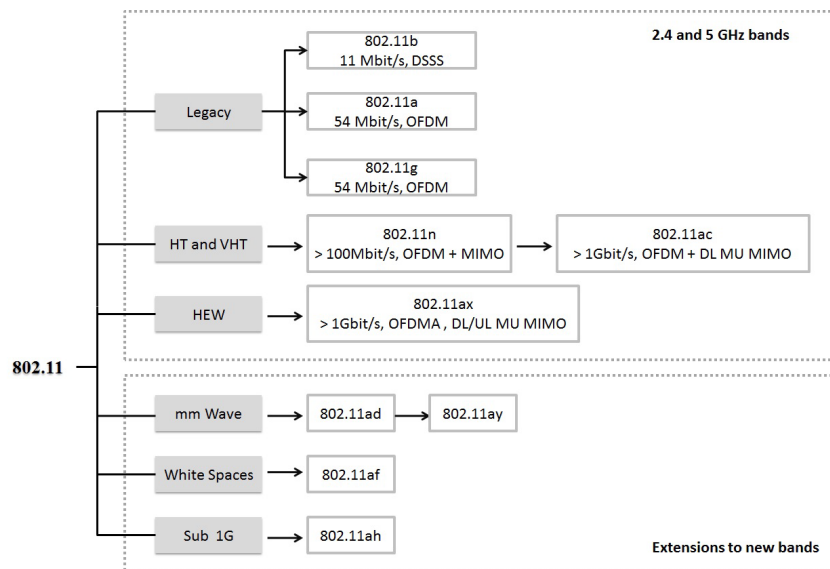

FIGURE 5. Wi-Fi technology evolution.

that will be available for low range applications within a room. The current 60 GHz standard provides data rates of up to 7 Gb/s. The next generation 60 GHz standard, 802.11ay, seeks to push data rates up to 20-40 Gb/s with an extended transmission distance of 300–500 meters. Channel bonding and MU-MIMO technologies are supported. IEEE 802.11ay is expected to be released also in 2019.

IEEE 802.11af, also known as White-Fi or Super Wi-Fi, allows Wi-Fi operation in TV white space spectrum in the VHF and UHF bands. It adopts cognitive radio technology to identify unused TV channels, based on an authorized geolocation database. This database provides information on the frequency, time and conditions that networks may operate. IEEE 802.11af was approved in February 2014.

IEEE 802.11ah, also known as Wi-Fi HaLow, allows Wi-Fi operation in sub 1 GHz license-exempt bands to provide long range and high power efficiency Wi-Fi networks for smart grid or Internet of Things (IoT) applications. IEEE 802.11ah is intended to be competitive with Bluetooth with its low power consumption, but with a wider coverage range.

V. EXPECTED FEATURES OF IEEE 802.11ax

IEEE 802.11ax aims to define standardized modifications to both PHY and MAC that enables at least one mode of operation capable of supporting at least four times improvement in the average throughput per station in dense deployment scenario, while maintaining power efficiency. In this section, we present the key technologies emerging on the horizon for IEEE 802.11ax PHY and MAC respectively.

TABLE 2. Comparison among 802.11 amendments PHY standard.

Amendment	Band	Max Rate	Waveform	MIMO	Channel Width	Coding	Range
a	5 GHz	54 Mb/s	OFDM	N/A	20 MHz	BCC	100 m
b	2.4 GHz	11 Mb/s	DSSS	N/A	20 MHz	BCC	100 m
g	2.4 GHz	54 Mb/s	OFDM	N/A	20 MHz	BCC	100 m
n	2.4/5 GHz	600 Mb/s	OFDM	4x4	20/40 MHz	BCC and LDPC	100 m
ad	60 GHz	7 Gb/s	OFDM	N/A	2 GHz	BCC and LDPC	10 m
ac	5 GHz	6.9 Gb/s	OFDM	8x8	20/40/80/160 MHz	BCC and LDPC	100 m
af	700 MHz	569 Mb/s	OFDM	4x4	6,7 and 8 MHz	BCC and LDPC	1 Km
ah	<1 GHz	346 Mb/s	OFDM	4x4	1/2/4/8/16 MHz	BCC and LDPC	1 Km
ay	60 GHz	TBD	OFDM	4x4	8 GHz	BCC and LDPC	10 m
ax	2.4/5 GHz	TBD	OFDMA	TBD	20/40/80/160 MHz	BCC and LDPC	100 m

BCC: Binary Convolutional Code, LDPC: Low Density Parity Check

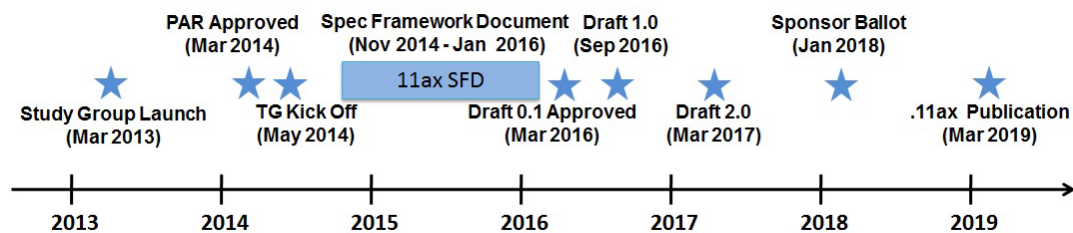
**FIGURE 6.** 802.11ax timeline.

A. OFDMA PHY

A good approach to alleviate the intensive contentions and to fully use the radio resource is to divide the whole frequency spectrum into small slices, call resource unit (RU), and mobile stations adapt different set of RUs and transmit their frames on the assigned RUs simultaneously. Hence, it is suggested that IEEE 802.11ax MAC should be able to work well with multiuser PHY technology and fully use the un-contiguous bandwidth.

Multiuser PHY allows multiple users to share the RUs centered at one single carrier frequency. In a given frequency band, there usually exist multiple carrier frequencies and thus multiple sub-carrier-time planes of RUs. Via proper radio resource allocation and optimization at scheduler, channel efficient transmission is enabled, which is adopted in Worldwide Interoperability for Microwave Access (WiMAX) and 3GPP Long-Term Evolution (LTE) and LTE-Advanced (LTE-A) cellular systems. Hence, to maximize the channel utilization and to support both uplink/downlink (UL/DL) MU transmission, in IEEE 802.11ax, orthogonal frequency-division multiple access (OFDMA) has been adopted as PHY layer protocol.

The introduction of OFDMA PHY into IEEE 802.11ax enjoys advantages of mature high-efficient PHY and smooth hybrid integration with cellular systems as heterogeneous wireless communication networks. On the other hand,

OFDMA PHY creates a new and fundamental challenge in IEEE 802.11ax MAC design. The major interaction between MAC and PHY lies in adaptive modulation and coding (AMC) and CCA. Current IEEE 802.11 adopts single-user PHY that actually transmits data through all data sub-carriers of the single carrier frequency at one time, and thus CSMA/CA protocol can perfectly work. The CCA can also be reliably executed because energy detection based signal processing can serve straightforward facilitation of CCA. However, CCA and thus CSMA/CA might face new challenges in OFDMA PHY as we can clearly observe that one user occupies a specific carrier frequency does not necessarily imply non-permissible for other users to access the RUs at this carrier frequency. For example, as shown in Fig. 7, purple RUs being used by user_i suggests that energy detection is on and carrier locking is on, but, in fact, user_j can still use yellow or green RUs, though the CCA is negative to prohibit using these carrier frequency as CSMA/CA operation, where different colors means different sub-carrier-time place of RUs at different carrier frequencies. Hence, enjoying reliable CCA to deploy CSMA/CA for two decades is now becoming an obstacle.

B. HE MAC SUBLAYER

Based on the above observations, a different thinking on MAC design for IEEE 802.11ax is required, to innovate a new

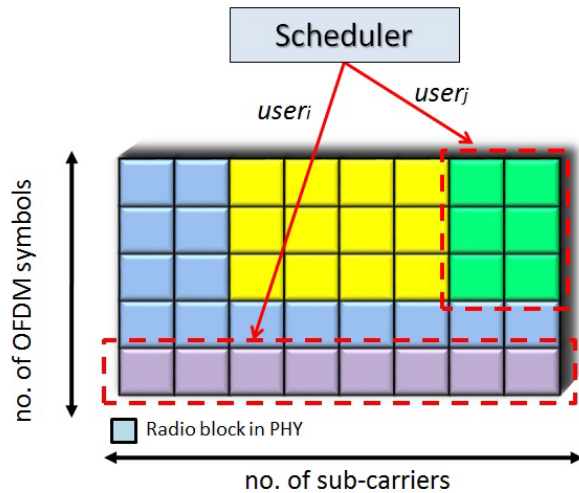

FIGURE 7. OFDMA PHY and challenges on CCA.

MAC protocol for multiuser OFDMA PHY in both downlink and uplink, while backward compatible with the original MAC based on CSMA/CA.

By looking into fundamental aspects of multiple access, inspired by R.G. Gallager’s research [20], multiple access protocol design has two basic mechanisms: carrier sensing and collision resolution. In general, the only possibilities to know availability of radio resources in multiuser PHY are either existence of a control channel or centralized allocation of RUs since the physical channel was logically divided into groups of RUs. Hence, in the new MAC design, when stations want to compete and utilize the available radio resources, we should abandon the concept of channels. Sensing the carrier is to learn the existence of radio resources and accessing the channel is to utilize portion of available radio resources. That is, centralized allocation of radio resources might be the most possible and feasible solutions to avoid collisions and to improve channel efficiency in IEEE 802.11ax WLANs.

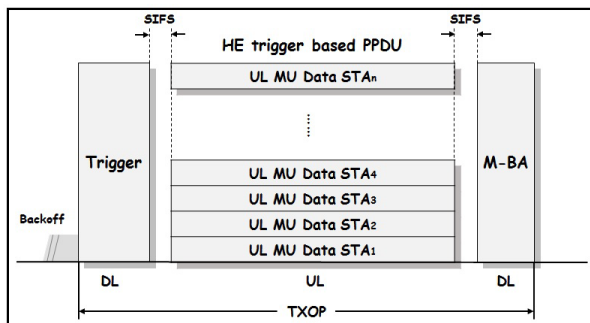

FIGURE 8. An example of UL MU transmission.

Fig. 8 illustrates an example of a TXOP containing UL MU transmissions with an immediate multi-station block-ack (M-BA) frame acknowledging the MAC protocol data

unit (MPDUs) that were correctly received from each IEEE 802.11ax station, i.e., high efficiency (HE) STA [21]. The operation is summarized as follows:

1). In order to gain control of the medium and collect traffic information from HE STAs, HE AP performs the function of the coordinator and starts to contend the channel by broadcasting a Trigger frame for random access (TF-R) after sensing the medium to be idle for a specific IFS period (PIFS or DIFS). In power save mode, the transmission time of Trigger frame can be indicated by corresponding beacon frame. The process of random access (RA) will be explained in detail in section VI.B.

2). Once receiving the TF-R frame, every active HE STA randomly selects any one of the assigned RUs for random access and simultaneously transmit their buffer status report (BSR) to HE AP. If necessary, HE AP could ask HE STA to send channel quality indicator (CQI) and radio measurement service along with buffer status information.

3). HE AP listens to these buffer status information simultaneously. When the HE AP receives bandwidth requirements correctly from at least one HE STA indicated by TF-R frame, the frame exchange initiated by the TF-R frame is successful.

4). HE AP coordinates the packet transmissions and allocates radio resource (RUs) to HE STAs. That is, HE AP maintains a polling list for registered HE STAs and polls them according to the list. The resource allocation information is included in Trigger frame (TF). The time for transmitting HE trigger based PLCP protocol data unit (PPDU) shall be explicitly indicated by HE AP in the TF frame.

5). Registered HE STAs simultaneously transmit their packets on the allocated RUs. When the HE AP receives the packets (HE trigger based PPDU) correctly from at least one HE STA indicated by TF frame, the frame exchange initiated by the TF frame is successful.

6). An HE AP/STA may send a multi-STA BlockAck frame (M-BA) in response to an HE trigger-based PPDU. A M-BA frame contains one or more BA information fields with one or more Association IDs (AIDs) and one or more different traffic IDs (TIDs). ACK or Block ACK (BA) frame may be aggregated with a DL HE MU PPDU or a TF frame to deliver the acknowledgement information to the corresponding stations. Fig. 9 illustrates an example of a TXOP containing an DL HE MU PPDU transmission with an immediate UL OFDMA acknowledgement [21].

As shown in Fig. 8, when a HE STA wants to establish a new connection, it can send its buffer status information (or BSR) in a randomly selected assigned RUs for RA. The RA process is for HE STAs with new request to compete transmission intent. When the HE STAs send out their buffer status information, HE AP will listen to these requests simultaneously. After that, the HE AP reserves the radio resource for HE STAs. Using the traffic information specified in assigned RUs for RA, HE AP coordinates resource allocation for UL transmission, and notifies it by transmitting TF frame. Each HE STA transmits its packets to the HE AP on the allocated RUs, and then the HE AP broadcast next TF frame

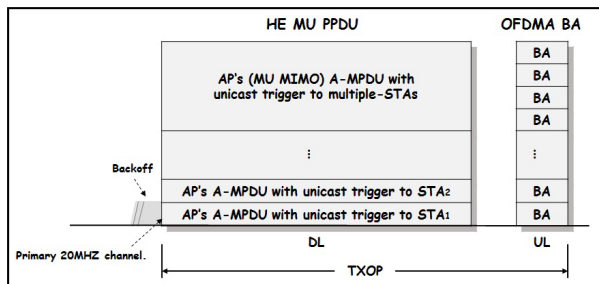

FIGURE 9. An example of DL MU transmission.

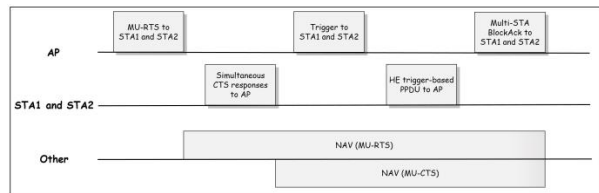

FIGURE 10. An example of MU-RTS/CTS procedure.

to deliver new scheduling information and acknowledgement information to the corresponding HE STAs.

The MU-RTS/CTS procedure allows an HE AP to protect an MU transmission. An HE AP may transmit an MU-RTS frame to solicit simultaneous CTS responses from one or more HE STAs. Fig. 10 shows an example of the exchange of MU-RTS and simultaneous CTS responses to protect the scheduled HE trigger-based PPDU and M-BA frame [21].

The trigger information should include sufficient information to identify the HE STAs transmitting. As shown in Fig. 11, the trigger information fields include manage information for one or more recipients, and also carry common

information for all receiver [21]. Therefore, HE AP is able to transit DL MU PPDUs to trigger, acknowledge or deliver data to designated HE STAs. Trigger frame carries an indication of whether or not the carrier sensing is required for the HE STAs to transmit a UL MU PDU in response to a Trigger frame (CS required subfield). If a Trigger frame indicates that the carrier sensing is required, the HE STAs shall consider the channel status of the physical channel sensing (energy detection) and virtual carrier sense (NAV) before UL MU transmission in response to the Trigger frame. Otherwise, the HE STAs may transmit a UL MU PDU without the carrier sensing.

Now we explain how the IEEE 802.11ax stations can coexist with the legacy IEEE 802.11 stations. The basic idea is that HE AP can save some portion of time allocated to the legacy stations. Besides, the HE STAs have to content the channel usage just like legacy stations. Hence, once the UL/DL SU/MU transmission for the HE STAs completed, legacy stations are able to content the channel usage and send their frames after ensuring that the channel is idle for DIFS duration. The HE AP/STA may set the duration field in the frames to announce the duration of the time occupied by the HE SU/MU PDU transmission. Upon receiving the frame, the legacy stations update their NAVs and avoid sending their packets in the specified time duration, thereby making IEEE 802.11ax stations to coexist with legacy IEEE 802.11 stations in one BSS. We depict an illustration to explain how the IEEE 802.11ax stations can coexist with the legacy IEEE 802.11 stations. Fig. 12 shows an example of frame exchange in IEEE 802.11ax WLAN, where a BSS consists of one HE AP and several mobile stations, including both HE STAs and legacy stations. Fig. 13 shows the station's state transition diagram of HE STA.

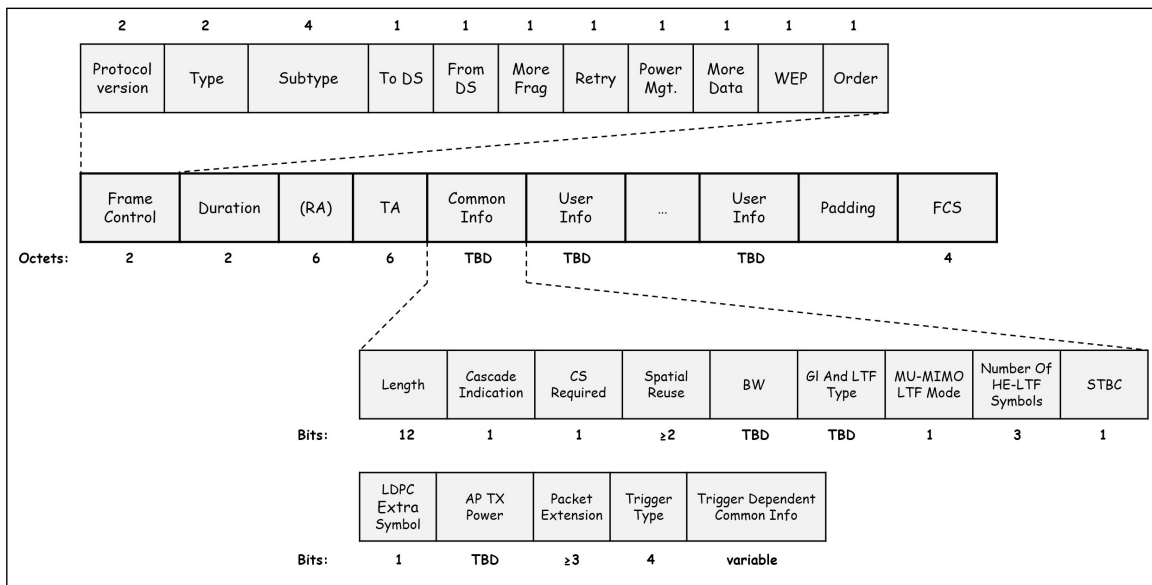

FIGURE 11. Trigger frame format.

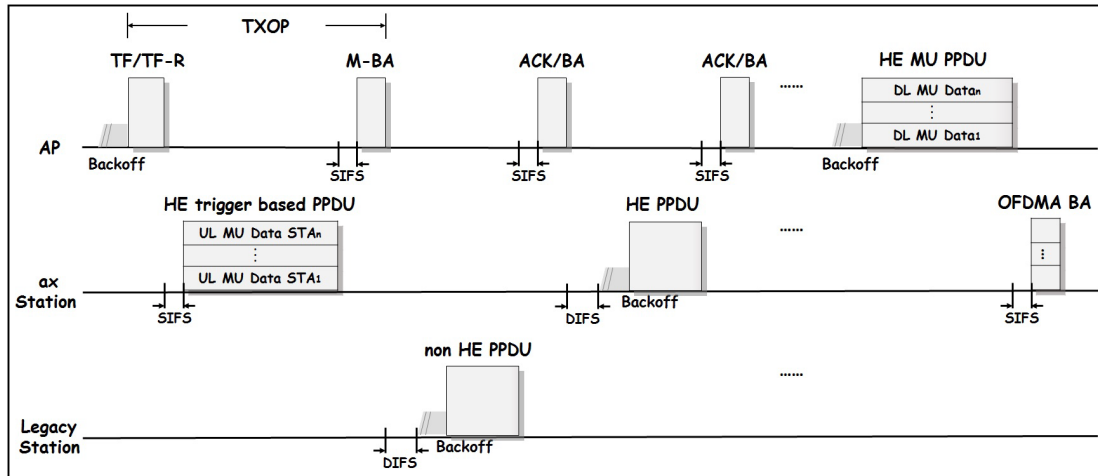

FIGURE 12. An example of frame exchange in IEEE 802.11ax WLAN.

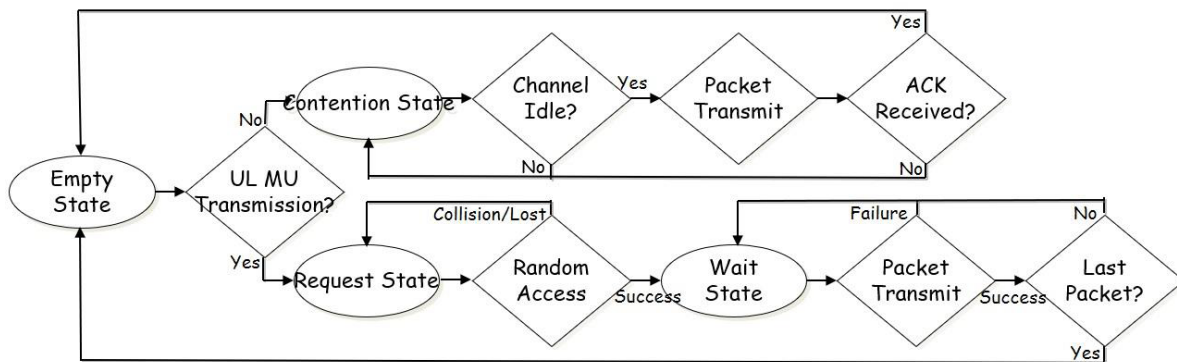

FIGURE 13. HE STA's state transition diagram.

VI. DESIGN ISSUES OF QoS PROVISIONING IN IEEE 802.11ax

The presence of QoS support in WLANs is crucial since a global, ubiquitous wireless network will play a vital role in creating new user-centric communication services in the future mobile Internet. In this section, we address design issues for QoS support in IEEE 802.11ax, toward the entire design of next generation WLANs. Please note that this represents our views and observations. However, some of these technologies are not included in the IEEE 802.11ax standard yet.

A. OFDMA NUMEROLOGY AND PHY PARAMETER

Plurality of traditional WLAN devices (IEEE 802.11 a/b/g/n) are currently operating at 2.4 GHz, crowding the channels and causing bandwidth crunch. Hence, as the further evolutionary version of IEEE 802.11ac, IEEE 802.11ax is suggested specified operating at 5 GHz ISM band for minimum interference and maximum available bandwidth. Besides, IEEE 802.11ax must be backward compatible with IEEE 802.11n at 5 GHz ensuring the interoperability of new and the already deployed IEEE 802.11n devices. Needless to say, IEEE 802.11ax shall

continue the use of MIMO technology based on IEEE 802.11ac technology. However, some key changes might be able to boost theoretical data rate depending on modulation, channel bandwidth, and MIMO configuration. For example, some IEEE 802.11ax usage scenarios are outdoor, but the current IEEE 802.11ac numerology, 312.5 kHz subcarrier frequency spacing, 3.2us IDFT/DFT period, and 0.8us guard interval (GI), cannot support outdoor channel environment since, according to our studies, simulation results of frame error rate show severe performance degradation in UMi non-line-of-sight (NLOS) channel. Hence, large delay spread with the outdoor channel environment results in requirement of longer GI, and extending the (Inverse) Discrete Fourier Transform (IDFT/DFT) period is necessary because it can reduce the overhead caused by longer GI. Table 3 summarizes the most important OFDMA numerology and PHY parameter in IEEE 802.11ax.

B. IEEE 802.11ax RANDOM ACCESS PROTOCOL

According to different traffic and service requirements, any random access protocol can be used for random access in IEEE 802.11ax WLAN. However, instead of contending the

TABLE 3. OFDMA numerology and PHY parameters in IEEE 802.11ax.

Bands	2.4GHz/5GHz
Channel Bandwidth	20MHz/40MHz/80MHz/80+80MHz/160MHz
FFT sizes	256/512/1024/2048
Modulation	BPSK/QPSK/16-QAM/64-QAM/256-QAM/1024-QAM
Subcarrier frequency spacing	78.125KHz
IDFT/DFT period	12.8us
Guard interval duration	0.8us/1.6us/3.2us
OFDM symbol duration	13.6us/14.4us/16us

medium in time domain, multiple HE STAs should be able to contend the medium in frequency domain to solve the bandwidth wastage due to collision(s), if multiuser PHY is adopted. The random access procedure proposed in IEEE 802.11ax applies UL OFDMA-based random access mechanism, as illustrated in Fig. 14.

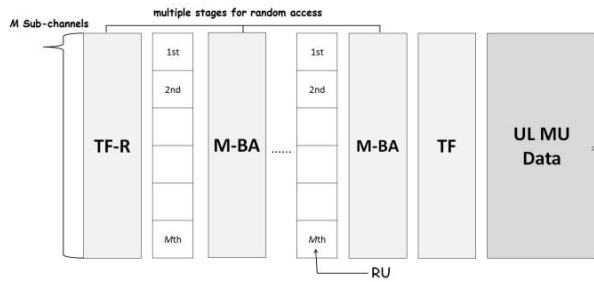

FIGURE 14. IEEE 802.11ax random access protocol.

In TF-R frames, the HE AP announces the number of stages and the number of assigned RUs for random access. If a HE STA has bandwidth requirement or BRS to send, it will wait for a random time donated by OFDMA Back-off (OBO) Count. The OBO is an integer value that corresponds to a number of RUs. First, a HE STA initializes an OBO in the range of 0 to OCW-1, where OCW (OFDMA contention window) is an integer with an initial value of OCW_{min}. After receiving TF-R frame, the HE STA decrements its OBO until reaching zero. When the timer decrements to zero, the HE STA randomly selects a RU in the corresponding stage and transmits its bandwidth requirement (or BSR). If the HE STA receives an ACK from HE AP, OCW will be reset to the minimum value of OCW (OCW_{min}). If two or more HE STAs select the same RU to send out their bandwidth requirement, a collision will occur, and OCW will grow in the form of min(OCW+OCW_{min}, OCW_{max}), where OCW_{max} is the maximum values of OCW. After collecting the information of bandwidth requirements from HE STAs, AP will send the packet scheduling information to HE STAs in the next TF frame.

Fig. 15 illustrates the IEEE 802.11ax random access procedure in detail [22]. As shown in Fig. 15, HE STA₁ and HE STA₂ decrement their non-zero OBO counters by 1 in every RU assigned for random access within the TF-R frame. As mentioned above, if the OBO counter for an HE STA is zero

or if the OBO counter decrements to 0, the HE STA randomly selects any one of the assigned RUs and transmits its UL PPDU in the selected RU. Otherwise, the HE STA resumes with its OBO counter in the next TF-R frame for random access. For example, in Fig. 15, STA₃ wins contention in first TF-R, randomly selects RU₃ in the TF-R, and STA₂ wins contention at RU₂ in second T-FR, randomly selects RU₁ in the TF-R.

Next, we present an analytical model that estimates the system efficiency and theoretical upper bound of IEEE 802.11ax random access protocol. Assuming there are N contending HE STAs and M RUs for transmitting bandwidth requirements (BSR) in one stage. Since the system efficiency is the ratio of successfully transmitted bandwidth requirements over number of RUs for RA, the system efficiency of IEEE 802.11ax WLAN RA protocol can be defined as follows:

$$\text{System Efficiency} = \frac{\# \text{ of successful BRs}}{\# \text{ of RUs for contending}} \quad (1)$$

In order to exploit the information about the actual system status, we define $n_j(t)$ to be the total number of BSRs transmitted by j^{th} station before stage t . We obtain:

$$\text{System Efficiency} = \frac{\sum_{j=1}^N \sum_{i=1}^{n_j(t)} \mathbb{1}\{\text{ith transmission of } j\text{th station is successful}\}}{M_t} \quad (2)$$

Let G be average attempt rate per stage, i.e., the average number of BSRs transmitted in a stage, and P_s be the successful probability per transmission. In long term, the system efficiency is therefore asymptotically given by

$$\frac{\left[\sum_{j=1}^N \frac{n_j(t)}{t} \right] \left[\frac{\sum_{i=1}^{n_j(t)} i_{ij}}{n_j(t)} \right]}{M} \rightarrow \frac{G P_s}{M}, \quad \text{as } t \rightarrow \infty \quad (3)$$

Assume that each HE STA has identical transmission probability τ for a given stage. Hence, replace G by $N\tau$ in (3), we can obtain the system efficiency of IEEE 802.11ax RA protocol given as

$$\frac{N\tau \left(1 - \frac{\tau}{M}\right)^{N-1}}{M} \quad (4)$$

The analytical model given above is very convenient to determine the optimal (maximum) system efficiency. It is clear that, from equation (4), the normalized system efficiency depends on the transmission probability τ . Hence, taking the derivative of equation (4) with respect to τ , and imposing it equal to 0, we obtain:

$$\frac{\delta}{\delta\tau} \frac{N\tau \left(1 - \frac{\tau}{M}\right)^{N-1}}{M} = \frac{N\tau \left(1 - \frac{\tau}{M}\right)^{N-1}}{M} + \frac{-N\tau (N-1) \left(1 - \frac{\tau}{M}\right)^{N-2}}{M^2} = 0$$

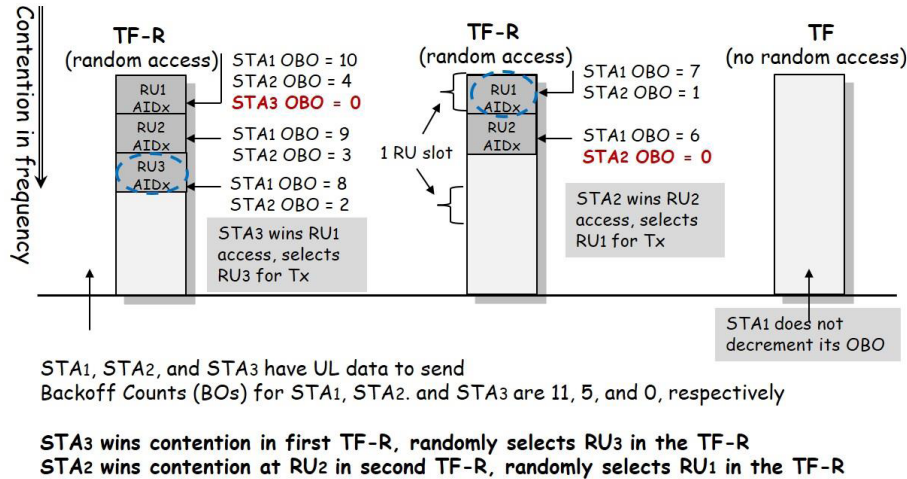

FIGURE 15. Illustration of the IEEE 802.11ax random access procedure.

which suggests

$$\tau = \frac{M}{N} \quad (5)$$

By substituting the result in equation (5) into equation (4), we obtain:

$$\frac{N_{\tau}(1 - \frac{\tau}{M})^{N-1}}{M} \Big|_{\tau = \frac{M}{N}} = (1 - \frac{1}{N})^{N-1} \quad (6)$$

This result shows that the optimal (maximum) system efficiency of IEEE 802.11ax RA protocol converges to e^{-1} as the number of contending increases, if optimal value of OCW size is adopted.

C. PRIORITY SUPPORT FOR IEEE 802.11ax RA PROCEDURE

In general, network administrators have two major types of QoS techniques. They can negotiate and reserve some portion of bandwidth for high priority traffic (known as hard QoS). However, when reserved and unused, bandwidth is wasted, and this is where priority scheme comes in. They can prioritize data without reserving any bandwidth (known as soft QoS). In 1999 Deng *et al.* introduced the priority scheme for IEEE 802.11 DCF access method and showed that priority can be supported by allocating a smaller CW size or a smaller IFS [5]. However, the purpose of priority scheme for IEEE 802.11ax RA procedure is quite different from the priority scheme proposed in [5] or EDCA access method proposed in IEEE 802.11e [8], as the priority scheme used in IEEE 802.11ax RA procedure is mainly for HE STAs to send their bandwidth requirement (BSR) to HE AP or to establish a new connection, but not for transmitting frames. Please note that, in IEEE 802.11ax WLAN, both DL/UL MU transmissions are scheduled by HE AP, and hence hard QoS guaranteed can be provided by HE AP, if there is no legacy IEEE 802.11 station exist to contend the channel.

In this subsection, we propose a multi-level priority scheme for the HE STAs to send their BSR or to establish a new connection for RA procedure. Since the station travels while a connection is alive, the QoS might degrade because of some physical constraints. The problem will become even more challenging because recent WLANs have been implemented using architecture based on small-size cells in dense deployment to obtain higher system throughput. Hence, in our design, the probe request for HE STA initial association and re-association has the highest priority among all other requests, and the second priority class is the voice, video (live streaming), and interactive-gaming traffic. Third priority class is the video traffic (buffered streaming), and then Internet application is in the fourth priority class. The channel quality indicator (CQI) and other radio measurement service will reside on the lowest priority level, as illustrated in Table 4.

TABLE 4. Access category for IEEE 802.11ax random access procedure.

Priority	Traffic type
1	Probe request
2	Voice, Video (live streaming), Interactive gaming
3	Video (buffered streaming)
4	Internet application
5	Channel quality indicator (CQI), Radio measurement service

D. CAC AND PACKET SCHEDULING POLICY FOR HE AP

Call admission control (CAC) is a crucial part of any QoS implementation since it serves for the purpose of deciding whether a network accepts a new connection or not. The CAC considers the expected latency of new connection and its effect on existing sessions upon arrival of new connection for admission decision to ensure that the channel is not overloaded and the delay constrains are not violated. Except CAC, another important component is the packet scheduling

policy, which is used by the HE AP to determine which HE STA gets permission to next transmit a packet. The packet scheduling policy should derive sufficient conditions such that all accepted connections satisfy their delay constraints to provide QoS guarantees for every single packet in WLANs. In this preliminary study, round-robin scheduling policy is suggested if HE STAs with homogeneous traffic characteristic and identical service requirements. On the other hand, earliest deadline first (EDF) scheduling policy is suggested if HE STAs with multimedia traffic. EDF is a dynamic scheduling algorithm widely used in real-time system. Whenever the scheduler selecting a packet to be transmitted, the transmission queue will be searched for the packet closest to its transmission deadline, and this packet is the next to be scheduled for transmission.

When serving the periodical traffic, the HE AP should allocate RUs for this HE STA periodically, if the more bit (piggyback) was set or the transmitting packet is not the last packet (end-of-file). When serving the bursty traffic or un-periodical traffic, the HE AP should continuously allocate RUs for this HE STA if the more (piggyback) bits was set. If the more bits were not set and the transmitting packet is not the last packet (end-of-file) either, the HE AP shall not allocate RUs for this HE STA until receiving the BSR from this HE STA once again. However, in such case the HE STA shall have priority when sending its BSR if with multimedia traffic, as defined in Table 4.

Finally, in IEEE 802.11ax WLAN, new traffic differentiation mechanism shall support more traffic types in order to satisfy better QoS expectations. Each traffic type is characterized by a mandatory set of QoS parameters, which is tailored to best describe the guarantees required by the applications that the service is designed for. Furthermore, IEEE 802.11ax shall focus more on latency or quality-of-experience (QoE) for Internet applications, in addition to QoS.

E. BANDWIDTH MANAGEMENT STRATEGY

In our view, HE AP should have priority to access the channel to send Trigger (TF/TF-R) frame by waiting PIFS period, or AP should be able to choose any access category to contend the channel when the AP sends Trigger frame so that the multimedia application can be supported in IEEE 802.11ax WLAN since a real-time connection usually requires higher priority than pure data. However, as the number of HE STAs generating high priority traffic increases, they tend to grab the channel. Hence, from the system performance viewpoint, it is equally important to guarantee a minimum bandwidth for data traffic or connections from legacy IEEE 802.11 stations in order to maintain a reasonable bandwidth usage. Hence, a simple and easy methodology to implement bandwidth management strategy should be proposed which not only tries to maximize the bandwidth utilization and reduce the blocking probability of real time connections but also guarantees a minimum bandwidth for data and traffic from legacy IEEE 802.11 stations.

F. DYNAMIC CCA AND TPC

The efficiency of legacy IEEE 802.11 WLAN does not scale in dense environments, due to the fact that severe collisions from channel contention and increasing interference from neighboring devices can seriously degrade the system performance. Besides, a constant CCA threshold, -82dBm , for all stations might create fairness problem among stations. In IEEE 802.11ax TG, dynamic CCA and transmission power control (TPC) are proposed to improve spatial reuse and overall system throughput in densely deployed WLANs. In general, a conservative configuration of CCA threshold and TPC level can reduce frame collisions and minimize the interference, but this could also reduce the number of concurrent transmissions. On the other hand, an aggressive configuration of CCA threshold and TPC level increases the number of concurrent transmissions at the cost of increasing collisions and interference. Hence, a distributed and dynamic algorithm which can appropriately tuning the CCA threshold and TPC level based on run-time measurement is the key to reach an optimal trade-off between collision probability and transmission opportunities [23]. However, as we mentioned, discussions on the related issues in IEEE 802.11ax TG are still at the early stage and there is no perfect solution proposed so far since an optimal CCA threshold and TPC level depends on multiple factors: frequency, topology, transmission power, even coexistence with legacy IEEE 802.11 stations.

G. OBSS MANAGEMENT

In dense legacy IEEE 802.11 WLAN, APs are usually assigned the same transmission channels due to the scarcity of available channels, and the legacy IEEE 802.11 does not include any channel resource allocation algorithm which allows APs to negotiate with each other to better allocate channel resources. In order to study the interference of legacy IEEE 802.11 WLAN in dense deployment, we used an event-driven custom simulation program, which is written by the C++ programming language, to observe the effect of how the AP interferes each other in OBSS environment. In the simulation APs are scared by Poisson Point Process (PPP) with density of 0.001 AP/m^2 , and the pathloss model is given by:

$$PL = 43.3 \log_{10}(d) + 11.5 + 20 \log_{10}(f_c \text{ GHz}) \text{ dB}$$

The transmission power and the CCA threshold are 30 dBm and -82dBm respectively. Simulation results are presented in Fig. 16. In Fig. 16, if there is a path between two APs, it means these two APs will effect/interfere each other in the long term.

In IEEE 802.11ax, the PHY preamble contains a 6-bits field named BSS color, which is the identification for the BSS and is randomly selected by the HE AP. When a HE STA receive a frame, it checks the BSS color. If the BSS color is the same, then the HE STA considers the frame as an inter-BSS frame, otherwise the HE STA considers the frame as an intra-BSS frame. In this way, the overall system throughput could be improved since the HE STAs ignore the

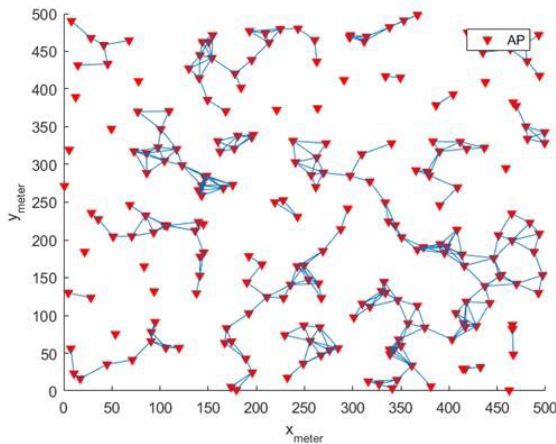

FIGURE 16. Interference between APs in densely deployed WLAN.

traffic from neighboring BSS to reduce unnecessary channel contention/interference in OBSS environment. Another way to improve the spatial reuse in OBSS environment is careful planning of channel allocation and AP position. Hence, an AP-initiated renegotiation mechanism shall be provided for IEEE 802.11ax in order to better allocated channel resources and improve spatial reuse in OBSS environment.

VII. LTE-LAA AND ITS IMPACTS TO QoS PROVISIONING IN IEEE 802.11ax

Due to the proliferation of smart phones and traffic hungry applications in recent year, wireless communication systems are facing severe traffic overloads and tremendous need of high bandwidth support. Now mobile operators are compelled to find new ways to significantly boost network capacity, reduce network congestion, provide better coverage, and save transmission energy. To cope with mobile data explosion, upgrading to 4G may be an immediate solution. However, the boom of smart phones and social media services has pushed cellular networks to their limits and it seems users' traffic demand is expected to exceed network capacity in the near future. The massive growth of global wireless technology has led to a massive increase in the value and demand for spectrum. Such an increasing need for a largely extended bandwidth has recently driven the development of technologies to utilize unlicensed bands. Some companies are now pushing the development of LTE-Unlicensed technology as a means to operate LTE in the same unlicensed spectrum used by Wi-Fi.

Needless to say, LTE-U may oppress Wi-Fi on unlicensed bands. Hence, LTE-U should try to avoid an aggressive behavior to degrade the QoS in Wi-Fi. On the other hand, the advantages of LTE-U can be diminished by the Wi-Fi operating in the same band, which should be an important issue considered by 3GPP.

Since 2015, 3GPP has launched standardization to deploy LTE-A networks to the 5 GHz unlicensed bands using the LAA technology in Release 13 and 14 [24]–[26]. With LAA,

an LTE-A network (also referred to as an LAA network) seems benefitting from a wider bandwidth. However, an LAA network may suffer from three unprecedented challenges to be deployed to unlicensed bands [26]. Firstly, different from the communications on the licensed bands where very limited regulations are imposed, transmissions on the unlicensed bands may be subject to various communications regulations. These communication regulations may include maximum transmission power, maximum channel occupation time, a certain level of power spectral density, etc. In Japan and Europe [27], the communication regulations further include the Listen-Before-Talk (LBT) scheme. In other words, any transmitter intending to transmit on the 5 GHz unlicensed bands needs to perform CCA before transmission. CCA should at least use the energy detection, and a transmission burst can take place only if the channel is sensed to be clear. Different from the IEEE 802.11 systems adopting contention based channel accesses, an LTE-A and thus an LAA network conventionally adopts a scheduling based radio access. As a result, how to include LBT into a scheduling based radio access may be a challenging issue. Secondly, for an LTE-A network deploying to the licensed band, there is no uncontrollable interference source, as LTE-A adopts a scheduling based radio access. However, for an LAA network deploying to the unlicensed bands, these two interference sources are uncontrollable by LAA: WiFi networks (IEEE 802.11a/ac/ax) and the weather radar systems. Thirdly, since an LAA transmitter and an LAA receiver may be geographically separated apart from each other, a clear channel sensed at the LAA transmitter side does not mean that the channel is also clear at the LAA receiver side, as shown in Fig. 17. This phenomenon is particularly known as the *LAA-WiFi hidden terminal problem*. In Wi-Fi networks, RTS and CTS messages are exploited to avoid the hidden terminal problem. However, without an air interface for information exchanges between Wi-Fi and LAA networks, this RTS-CTS exchange cannot be utilized.

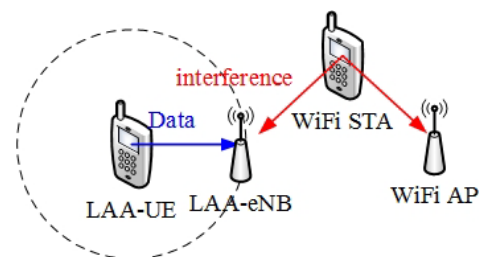

FIGURE 17. Although a clear channel is sensed by a LAA transmitter (LAA-UE, as an example), there may be interference at the LAA receiver (LAA-eNB, as an example).

Due to above three challenges, there could be severe interference between LAA and IEEE 802.11a/ac/ax. Consequently, to support QoS provisioning both in LAA and Wi-Fi, downlink and uplink channel access of LAA should be carefully designed, to avoid channel starvation on the unlicensed bands.

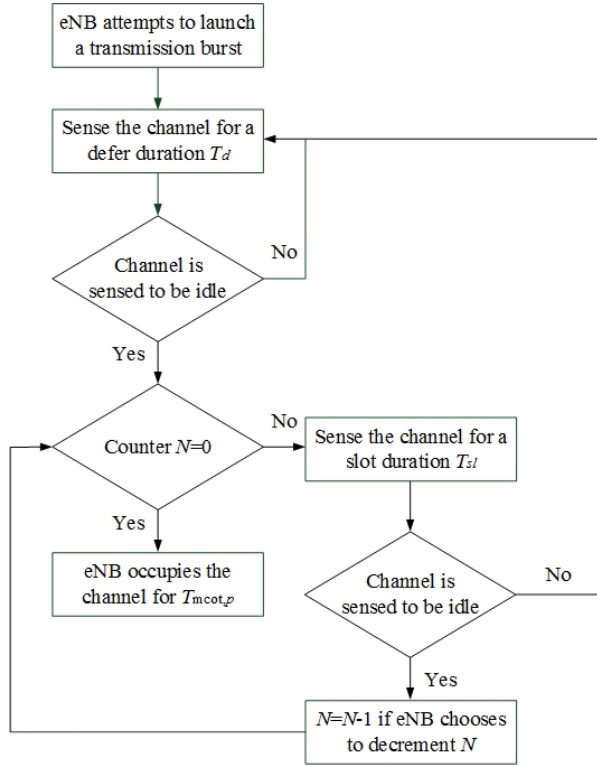

FIGURE 18. Downlink channel access of LAA.

A. DESIGN TARGETS OF LAA

To develop LAA, the following design targets have been agreed. 1) There should be a single global solution framework allowing compliance with any regional regulatory requirements. 2) LAA should effectively and fairly coexist with Wi-Fi. 3) An LAA network should effectively and fairly coexist with other LAA networks deployed by different operators. For these three design targets, the following mechanisms have been included as mandatory functions in the LAA designs.

- **Carrier aggregation (CA).** CA is the technology to integrate multiple (noncontiguous) component carriers (CCs) with different bandwidth into a single carrier with a larger bandwidth. There are two types of CCs in CA: primary CC (transmitting radio resource control signaling and data) and secondary CC (transmitting data with best effort services). In LAA, the primary CC is operated on the licensed bands, while the secondary CC(s) is operated on the unlicensed bands to support best effort services.
- **Listen-before-transmission (LBT).** An equipment applies a clear channel assessment (CCA) check before using the channel.
- **Discontinuous transmission on a carrier with limited maximum transmission duration.** For LAA, the maximum channel occupation time is 10 ms as a transmitter launches a transmission.

TABLE 5. Parameters of different traffic priorities in LAA downlink channel access.

Channel Access Priority Class p	m_p	$CW_{min,p}$	$CW_{max,p}$	$T_{mco,t,p}$	Allowed CW_p sizes
1	1	3	7	2 ms	(3,7)
2	1	7	15	8 ms	(7,15)
3	3	15	63	8 or 10 ms	(15,31,63)
4	7	15	1023	8 or 10 ms	(15,31,63,127,255,511,1023)

TABLE 6. Simulation parameters of Fig. 19 and Fig. 20.

Parameters/assumptions	values
Size of deployment area	160000 m ²
Number of eNBs	20
Number of UEs	80
Deployment of eNBs	Randomly and uniformly deployed
Deployment of UEs	Randomly and uniformly deployed. Each UE connects to the eNB with the strongest signal strength
Number of WiFi transmitters	30
Number of WiFi receivers	30
Deployment of WiFi transmitters	Randomly and uniformly deployed
Deployment of WiFi receivers	Randomly and uniformly deployed. Each receiver connects to the transmitter with the strongest signal strength, but each transmitter only connects to one receiver
TX power of each WiFi transmitter	15 dBm
TX power of each UE	10 dBm to 20 dBm
CCA-ED threshold of a WiFi transmitter	-62 dBm
CCA-ED threshold of an LAA	-72 dBm to -62 dBm

- **Dynamic frequency selection (DFS).** This mechanism is provided to change different carriers on a relatively slow time scale, so as to avoid interference to/from weather radar systems.
- **Dynamic carrier selection (DCS).** Since there is a large available bandwidth on the unlicensed spectrum, this function enables an LAA network to select a carrier with a lower interference level.
- **Transmit Power Control (TPC).** An equipment should be able to reduce the transmit power in a proportion of 3dB or 6dB compared to the maximum nominal transmit power.

To support all above functions, the downlink and uplink channel accesses of LAA are designed as follows.

B. DOWNLINK CHANNEL ACCESS OF LAA

To effectively and fairly coexist with Wi-Fi and to minimize the impacts to QoS of Wi-Fi, the downlink channel access is designed to be similar with the DCF of Wi-Fi, as illustrated in Fig. 18.

When an LAA eNB attempts to launch a transmission burst, the eNB needs to sense the channel for a defer

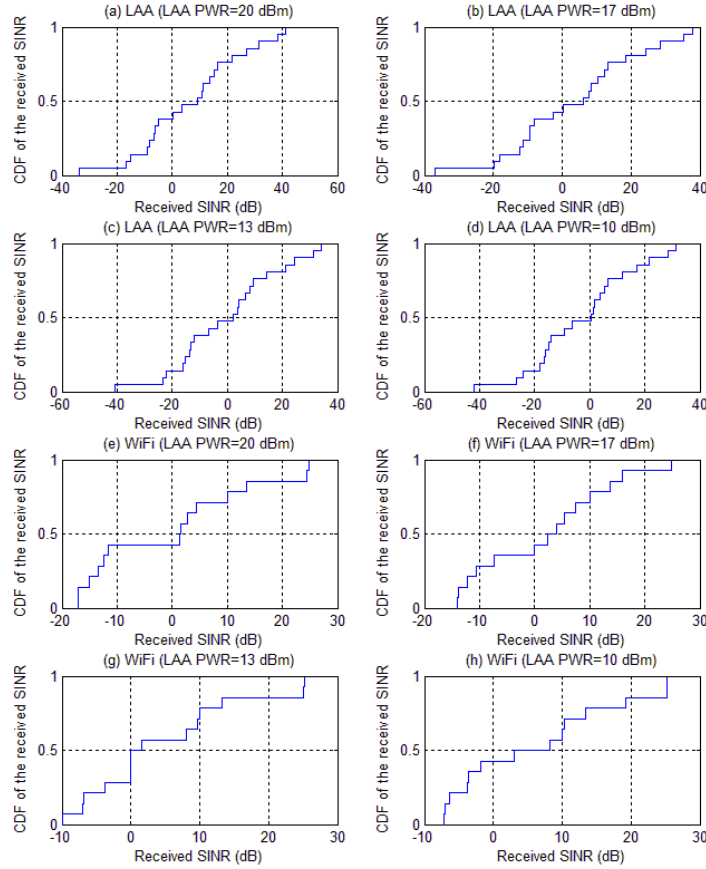

FIGURE 19. CDF of received SINR of all LAA-eNBs when transmission power of each LAA-UE is (a) 20 dBm, (b) 17 dBm, (c) 13 dBm, (d) 10 dBm, and CDF of received SINR of all Wi-Fi receivers when transmission power of each LAA-UE is (e) 20 dBm, (f) 17 dBm, (g) 13 dBm, (h) 10 dBm, as the energy detection threshold of LAA is -62 dBm.

period T_d , where T_d is composed of $T_f = 16\mu s$ and m_p CCA slots. The length of each CCA slots is $T_{sl} = 9\mu s$, and the value of m_p depends on the priority of transmitted traffic, as summarized in Table 5. If the channel is clear at this moment, then the eNB checks the value of a backoff counter N , where N is randomly selected from $[CW_{min,p}, CW_{max,p}]$. If $N = 0$, then a transmission burst can be launched to occupy the channel for a period of $T_{mcot,p}$; otherwise, the eNB should sense the channel for T_{sl} and set $N = N-1$ if the channel is idle. At any circumstance, if the channel is sensed to be busy, then the eNB should sense the channel for T_d .

C. UPLINK CHANNEL ACCESS OF LAA

Since LAA adopts a scheduling based radio access, an eNB needs to inform a user equipment (UE) the allocated time-frequency resources for uplink/downlink transmissions, such that a UE is able to transmit/receive data at the allocated resources. However, such a scheduling based radio access may harm the performance in terms of radio access latency in uplink transmissions when LBT is applied. To schedule a UE for uplink transmissions, if the eNB has downlink data to

be transmitted to the UE, the uplink scheduling information (indicating the time-frequency resource location for uplink transmissions) can be transmitted to the UE together with downlink data. However, if there is no downlink data to be transmitted to the UE, the eNB may transmit the uplink scheduling information using LBT, which may increase the delay of uplink transmissions. On the other hand, even though the uplink scheduling information can be transmitted to the LAA UE on time, the UE still needs to perform LBT on the allocated uplink resources, which also increase the delay of uplink channel access.

To significantly reduce the uplink channel access delay, the uplink channel access of LAA is similar to the downlink channel access, while using the channel access parameters of $CW_{max,p} \in \{3, 4, 5, 6, 7\}$ and $m_p = 1$. Other parameters will be further defined in Release 14. Please note that there is no intra-network interference in an LAA network, and therefore the spirit of such uplink design is to facilitate a UE such that a UE can have a better chance to access the channel as compared with an Wi-Fi station.

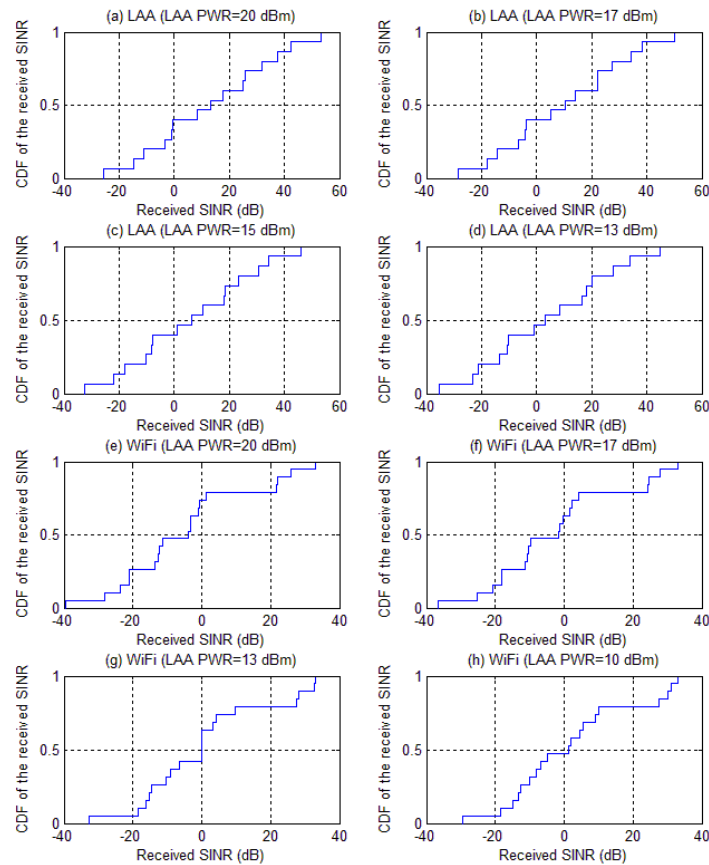

FIGURE 20. CDF of received SINR of all LAA-eNBs when transmission power of each LAA-UE is (a) 20 dBm, (b) 17 dBm, (c) 13 dBm, (d) 10 dBm, and CDF of received SINR of all Wi-Fi receivers when transmission power of each LAA-UE is (e) 20 dBm, (f) 17 dBm, (g) 13 dBm, (h) 10 dBm, as the energy detection threshold of LAA is -72 dBm.

D. OTHER DESIGN CONSIDERATIONS OF IMPACTS TO QoS OF Wi-Fi

WiFi systems are inherently asynchronous (i.e., there is no strong timing alignment between a transmitter and a receiver). In this case, a transmitter may insert a preamble at the beginning of a transmission burst, and a receiver should continuously detect the preamble to identify the presence of a transmission burst. For Wi-Fi, there are two types of CCA: carrier sensing and energy detection. The purpose of carrier sensing is to detect a signal transmitted by the same Wi-Fi system, and this purpose is usually achieved by detecting the presence of a preamble. In practice, to detect a preamble, the received power should exceed around -82 dBm. On the other hand, the purpose of energy detection is to detect the presence of other signals not transmitted from the same Wi-Fi system. For this purpose, the threshold shall be around 20 dB higher than that in carrier sensing.

LAA, however, is a synchronous system (i.e., there is a strong timing alignment between a transmitter and a receiver). For this system, a preamble is no longer needed in a transmission burst. As a result, CCA can be facilitated simply by the

energy detection. In LAA, the energy detection threshold is around -72 dBm (for a 20 MHz bandwidth), which can be further relaxed to a higher value.

In Fig. 19 and Fig. 20, the cumulative distribution functions (CDFs) of the received signal to interference and noise power ratio (SINR) of LAA receivers and Wi-Fi receivers for LAA-WiFi coexistence are provided. In Fig. 19, the energy detection thresholds of an Wi-Fi transmitter and an LAA transmitter are both fixed to -62 dBm. In Fig. 20, the energy detection thresholds of an Wi-Fi transmitter and an LAA transmitter are -62 dBm and -72 dBm, respectively. The parameters of simulations for Fig. 19 and Fig. 20 are listed in Table 6. We can observe from Fig. 19 and Fig. 20 that, the CCA energy detection threshold and transmission power of LAA may influence the Wi-Fi performance. To provide a fair coexistence of LAA and Wi-Fi, when the energy detection threshold of CCA decreases, it suggests that concurrent transmissions of Wi-Fi and LAA may not be allowed. In this case, transmission power of LAA should also be decreased as well, to facilitate spatial reuse of Wi-Fi. On the other hand, when the CCA energy detection threshold increases,

concurrent transmissions of Wi-Fi and LAA could be allowed, and therefore both Wi-Fi and LAA may suffer from stronger interference from each other. In this case, the transmission power of LAA should be increased to overcome interference.

As there are multiple energy detection threshold adjustment rules in the 5 GHz spectrum, the energy detection threshold adjustment of IEEE 802.11ax becomes a very challenging task. Since an energy detection threshold adjustment rule may significantly impact the capability of channel occupation and concurrent channel occupation, it is of crucial importance in QoS provisioning in terms of throughput and channel access delay. As a result, an energy detection threshold adjustment in IEEE 802.11ax must be carefully designed to optimize the system performance of IEEE 802.11ax, while to avoid unacceptable impacts to legacy systems (i.e., IEEE 802.11a/ax and LAA).

VIII. CONCLUSIONS

Providing QoS in WLANs is an intrinsically difficult task due to station mobility, distributed channel access, and fading radio signal effects. Ongoing efforts to provide perfect solutions have illustrated that attempts to solve all possible problems result in technologies that are far too complex, have poor scaling properties, or simply do not integrate well into the diversity of the Internet. In this paper we present the new technologies that may be included in IEEE 802.11ax. The design issues of providing QoS in the next generation WLAN protocol, IEEE 802.11ax, is also articulated. In addition, we summarize the IEEE 802.11ax and LTE-LAA standardization activities in progress. We hope researchers and engineers can easily comprehend the current perspectives and expected features on designing QoS in IEEE 802.11ax after reading this paper.

Devising a well-performing PHY and MAC protocol for new generation WLANs can be a challenging task of significant research interest. Of course, to facilitate this paradigm shift, many interesting research topics require further explorations, such as an analytical model that accurately evaluates the saturated/unsaturated throughput of normalized systems, a simple but efficient call admission control and packet transmission policy, the realm of providing QoS, cross layer optimization between PHY layer and MAC layer, and finally the optimized and fair coexistence mechanism between LTE-U (5G) and IEEE 802.11ax, since the next generation WLAN shall have flexibility to support spectrums sharing by treating Wi-Fi as cognitive radios under OFDMA PHY and to enable smooth vertical handover, good network economic efficiency, and spectrum sharing efficiency.

ACKNOWLEDGEMENT

The authors would like to thank Dr. Osama Aboul-Magd, Dr. Yingpei Lin, Mr. Jiayin Zhang, for the fruitful and useful technical discussions, which are of great help on preparing the paper. Thanks to Prof. Rung-Shiang Cheng for his help with building legacy IEEE 802.11 simulation environment.

REFERENCES

- [1] K.-C. Chen, "Medium access control of wireless LANs for mobile computing," *IEEE Netw.*, vol. 8, no. 5, pp. 50–63, Sep./Oct. 1994.
- [2] D. J. Deng, K. C. Chen, and R. S. Cheng, "IEEE 802.11ax: Next generation wireless local area networks," in *Proc. Qshine*, Aug. 2014, pp. 77–82.
- [3] G. Bianchi, "Performance analysis of the IEEE 802.11 distributed coordination function," *IEEE J. Sel. Areas Commun.*, vol. 18, no. 3, pp. 535–547, Mar. 2000.
- [4] B. Bellalta, "IEEE 802.11ax: High-efficiency WLANs," *IEEE Wireless Commun. Mag.*, vol. 23, no. 1, pp. 38–46, Feb. 2016.
- [5] D.-J. Deng and R.-S. Chang, "A priority scheme for IEEE 802.11 DCF access method," *IEICE Trans. Commun.*, vol. E82-B, no. 1, pp. 96–102, 1999.
- [6] D. J. Deng and H. C. Yen, "Quality-of-service provision system for multimedia transmission in IEEE 802.11 wireless LANs," *IEEE J. Sel. Areas Commun.*, vol. 23, no. 6, pp. 1240–1252, Jun. 2005.
- [7] H. Zhai, J. Wang, and Y. Fang, "Providing statistical QoS guarantee for voice over IP in the IEEE 802.11 wireless LANs," *IEEE Wireless Commun.*, vol. 13, no. 1, pp. 36–43, Feb. 2006.
- [8] *Part 11: Wireless LAN Medium Access Control (MAC) and Physical Layer (PHY) Specifications Amendment 8: Medium Access Control (MAC) Quality of Service Enhancements*, IEEE Standard 802.11e, 2005.
- [9] C.-Y. Chang, H.-Y. Yen, C.-C. Lin, and D.-J. Deng, "QoS/QoE support for H.264/AVC video stream in IEEE 802.11ac WLANs," *IEEE Syst. J.*, doi: 10.1109/JSYST.2015.2431291.
- [10] *Part 11: Wireless LAN Medium Access Control (MAC) and Physical Layer (PHY) Specifications Amendment 10: Mesh Networking*, IEEE Standard 802.11s, 2011.
- [11] *Part 11: Wireless LAN Medium Access Control (MAC) and Physical Layer (PHY) Specifications: Amendment 2: MAC Enhancements for Robust Audio Video Streaming*, IEEE Standard 802.11aa, 2012.
- [12] *Part 11: Wireless LAN Medium Access Control (MAC) and Physical Layer (PHY) Specifications: Amendment 1: Prioritization of Management Frames*, IEEE Standard 802.11ae, 2012.
- [13] M. A. Santos, J. Villalon, and L. Orozco-Barbosa, "A novel QoE-aware multicast mechanism for video communications over IEEE 802.11 WLANs," *IEEE J. Sel. Areas Commun.*, vol. 30, no. 7, pp. 1205–1214, Aug. 2012.
- [14] D.-J. Deng, C.-H. Ke, H.-H. Chen, and Y.-M. Huang, "Contention window optimization for IEEE 802.11 DCF access control," *IEEE Trans. Wireless Commun.*, vol. 7, no. 12, pp. 5129–5135, Dec. 2008.
- [15] N. Song, B. Kwak, and L. E. Miller, "Analysis of EIED backoff algorithm for the IEEE 802.11 DCF," in *Proc. IEEE Int. Conf. Veh. Technol.*, Sep. 2005, pp. 2182–2186.
- [16] L. Bononi, M. Conti, and E. Gregori, "Runtime optimization of IEEE 802.11 wireless LANs performance," *IEEE Trans. Parallel Distrib. Syst.*, vol. 15, no. 1, pp. 66–80, Jan. 2004.
- [17] Y. Zhu, Q. Zhang, Z. Niu, and J. Zhu, "On optimal QoS-aware physical carrier sensing for IEEE 802.11 based WLANs: Theoretical analysis and protocol design," *IEEE Trans. Wireless Commun.*, vol. 7, no. 4, pp. 1369–1378, Apr. 2008.
- [18] J. Liu, T. Wu, J. Wang, R. Huang, and J. Yee, *Considerations on OBSS Spatial Re-Use*, IEEE Standard 802.11-14/1435r0, P802.11ax Task Group Press Release, 2014.
- [19] S. Merlin et al., *TGax Simulation Scenarios*, IEEE Standard 802.11-14/0980r16, P802.11ax Task Group Press Release, 2015.
- [20] R. G. Gallager, "A perspective on multiaccess channels," *IEEE Trans. Inf. Theory*, vol. 31, no. 2, pp. 124–142, Mar. 1985.
- [21] *Part 11: Wireless LAN Medium Access Control (MAC) and Physical Layer (PHY) Specifications: Amendment 6: Enhancements for High Efficiency in Frequency Bands Between 1 GHz and 6 GHz*, IEEE Standard 802.11ax Draft 0.2, 2016.
- [22] C. Ghosh et al., *UL OFDMA-Based Random Access Procedure*, IEEE Standard 802.11-15/1105r0, P802.11ax Task Group Press Release, 2015.
- [23] M. S. Afaqui, E. Garcia-Villegas, E. Lopez-Aguilera, G. Smith, and D. Camps, "Evaluation of dynamic sensitivity control algorithm for IEEE 802.11ax," in *Proc. IEEE Wireless Commun. Netw. Conf. (WCNC)*, Mar. 2015, pp. 1060–1065.
- [24] *Feasibility Study on Licensed-Assisted Access to Unlicensed Spectrum*, document 3GPP TR 36.889 V1.0.1, Jun. 2015.
- [25] *E-UTRA Physical Layer Procedures*, document 3GPP TS 36.213 V13.2.0, Jun. 2016.

- [26] S.-Y. Lien, J. Lee, and Y.-C. Liang, "Random access or scheduling: Optimum LTE licensed-assisted access to unlicensed spectrum," *IEEE Commun. Lett.*, vol. 20, no. 3, pp. 590–593, Mar. 2016.
- [27] *Broadband Radio Access Networks (BRAN) 5 GHz High Performance RLAN*, document ETSI EN 301 893 V1.7.0, Jan. 2012.



DER-JIUNN DENG (M'10) received the Ph.D. degree in electrical engineering from the National Taiwan University in 2005. He joined the National Changhua University of Education as an Assistant Professor, Department of Computer Science and Information Engineering in 2005, and then became a Full Professor in 2012. His research interests include multimedia communication, quality-of-service, and wireless networks. In 2010, 2011, and 2012, he received the Research Excellency Award of the National Changhua University of Education. In 2012, he also received the Outstanding Faculty Research Award of National Changhua University of Education. Dr. Deng served or is serving as an Editor and a Guest Editor for several technical journals. He also served or is serving on several symposium chairs and technical program committees of the IEEE and other international conferences.



SHAO-YU LIEN received the B.S. degree from the Department of Electrical Engineering, National Taiwan Ocean University in 2004, the M.S. degree from the Institute of Computer and Communication Engineering, National Cheng Kung University, in 2006, and the Ph.D. degree from the Graduate Institute of Communication Engineering, National Taiwan University in 2011. After the military service, he joined the National Taiwan University as a Post-Doctoral Fellow, and the Massachusetts Institute of Technology, CA, as a Visiting Post-Doctoral Researcher in 2012. He has been with the Department of Electronic Engineering, National Formosa University as an Assistant Professor since 2013, and as an Associate Professor since 2016. Dr. Lien received a number of prestigious research recognitions, including the IEEE Communications Society Asia-Pacific Outstanding Paper Award 2014, the Scopus Young Researcher Award (Elsevier) 2014, the URSI AP-RASC 2013 Young Scientist Award, and the IEEE ICC 2010 best paper award. His research interests lie in optimization techniques for communication networks.



JORDEN LEE received the B.S. degree from the Department of Electrical Engineering, National Chiao Tung University in 2014. He is currently pursuing the M.S. degree with the Graduate Institute of Communication Engineering, National Taiwan University. His research interests include channel access for WLAN and game theory for wireless networks.



KWANG-CHENG CHEN (M'89–SM'94–F'07) received the B.S. degree from the National Taiwan University in 1983, and the M.S. and Ph.D. degrees from the University of Maryland, College Park, in 1987 and 1989, all in electrical engineering. From 1987 to 1998, he was with SSE, COMSAT, IBM Thomas J. Watson Research Center, and National Tsing Hua University, where he was involved in mobile communications and networks. From 1998 to 2016, he was a Distinguished Professor with the National Taiwan University, Taipei, Taiwan, where served as the Director of the Graduate Institute of Communication Engineering, Communication Research Center, and the Associate Dean for Academic Affairs, and visited the Massachusetts Institute of Technology from 2015 to 2016. Dr. Chen is currently a Professor with the Department of Electrical Engineering, University of South Florida, FL, USA. He has been actively involving in the organization of various IEEE conferences as a General/TPC Chair/Co-Chair, and has served in editorships with a few IEEE journals. He also actively participates in and has contributed essential technology to various IEEE 802, Bluetooth, and LTE and LTE-A wireless standards. Dr. Chen has received a number of awards, such as the 2011 IEEE COMSOC WTC Recognition Award, 2014 IEEE Jack Neubauer Memorial Award, and the 2014 IEEE COMSOC AP Outstanding Paper Award. His recent research interests include wireless communications, cybersecurity, cyber-physical systems, social networks and data science.

...